

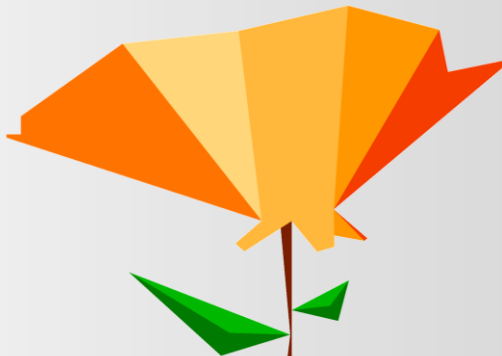

PREFEITURA  
**NITERÓI**  
FEITA POR VOCÊ



BANCO DE DESENVOLVIMENTO  
DA AMÉRICA LATINA



**PRO-SUSTENTÁVEL**

**PARQUE ORLA PIRATININGA**

**Proposta inicial de Projeto Básico**

**TRECHOS 8 e 9**

**18/06/2019**

# PARQUE ORLA PIRATININGA



# PARQUE ORLA PIRATININGA: Trechos





---

# URBANISMO

---



# PRINCIPAIS ACESSOS AO PARQUE



# INFRAESTRUTURA CICLOVIÁRIA

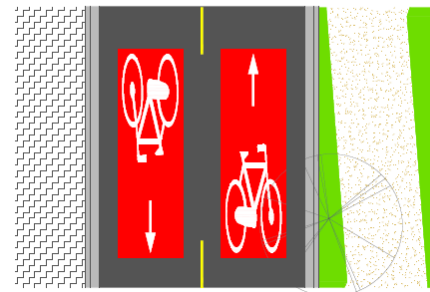
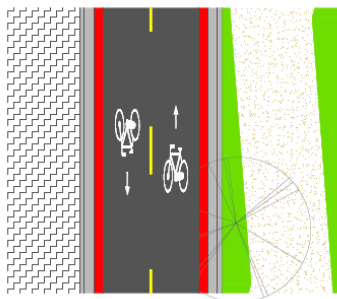
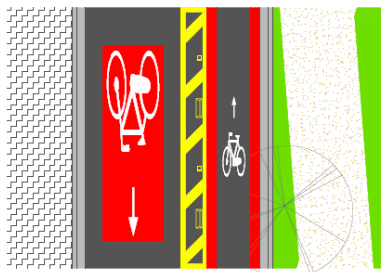
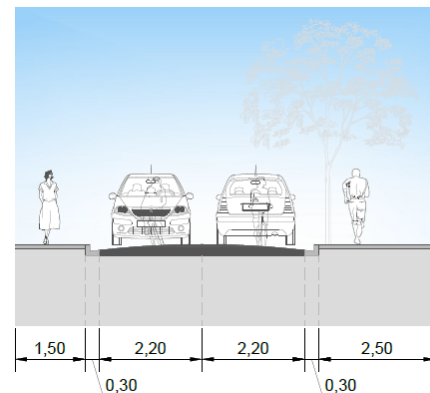
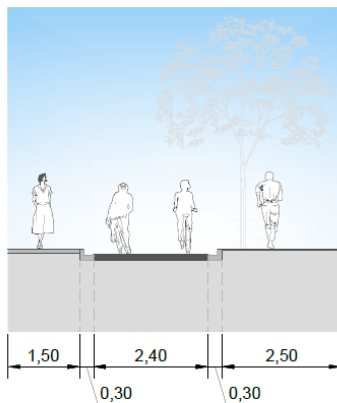
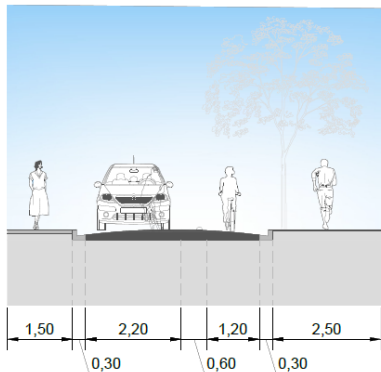

# INFRAESTRUTURA CICLOVIÁRIA

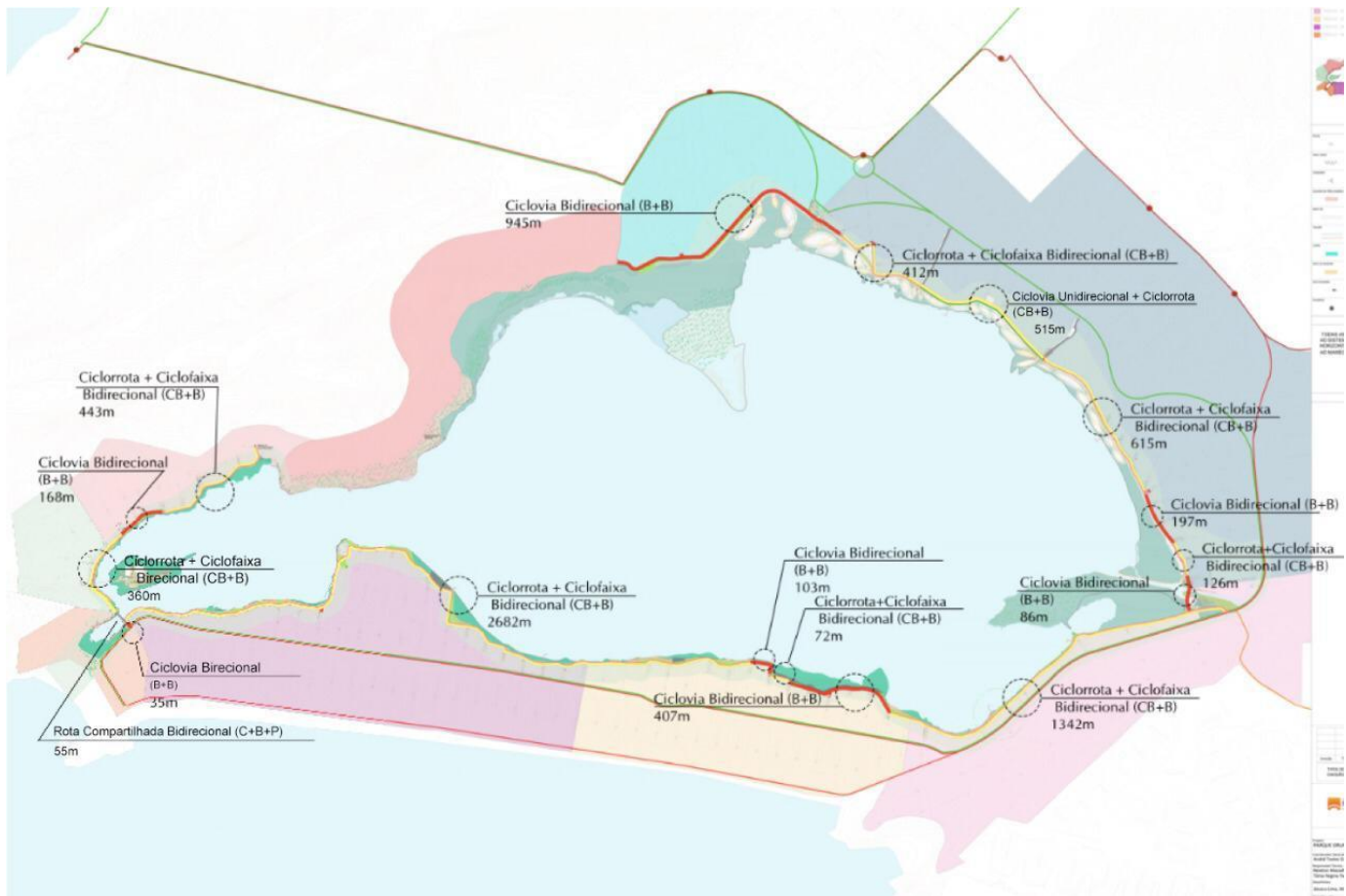

# ÁREAS DE LAZER

-  PIER DE CONTEMPLAÇÃO
-  PIER DE PESCA
-  ÁREA INFANTIL
-  ACADEMIA
-  QUADRA POLIESPORTIVA
-  CHURRASQUEIRA

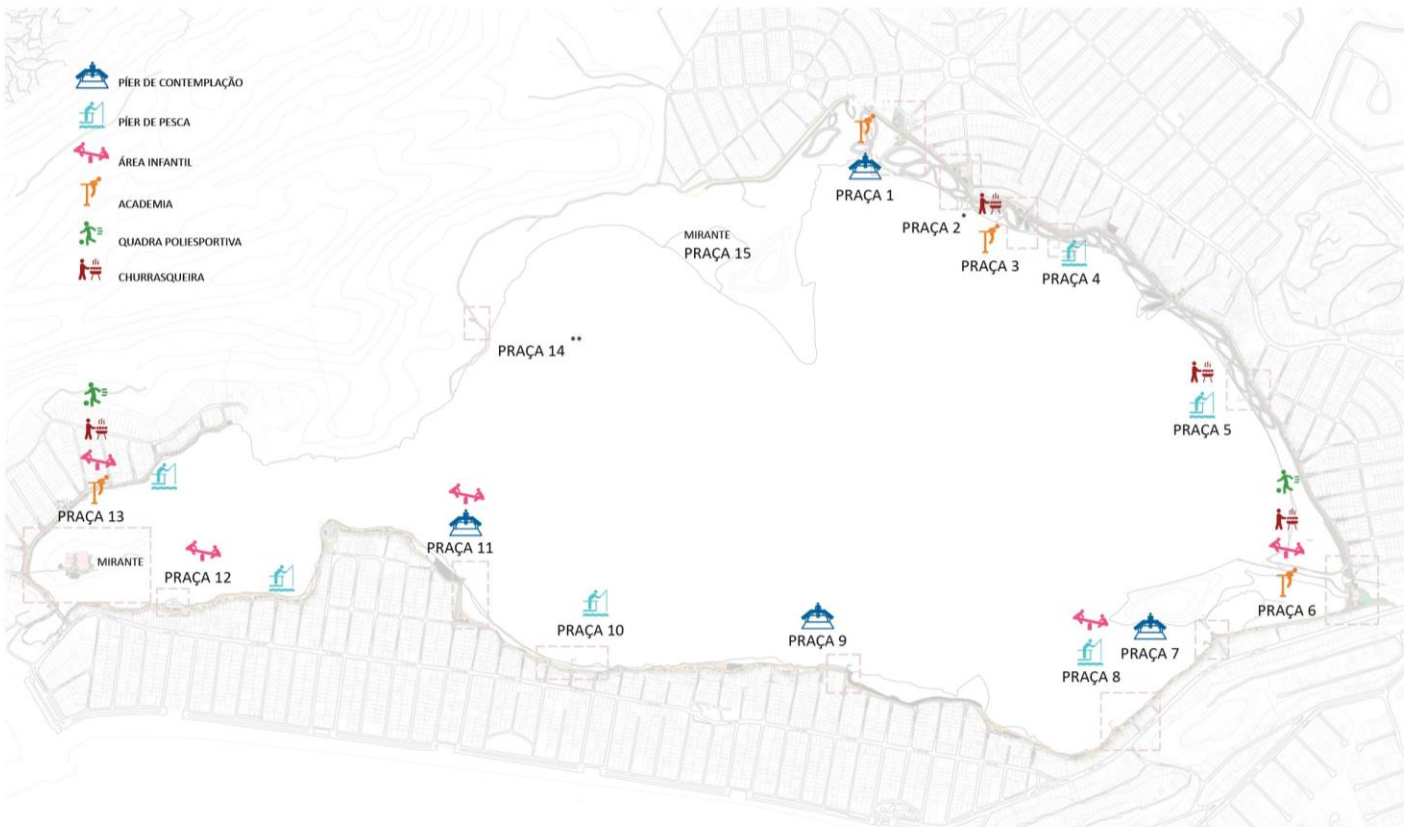



# PARQUE ORLA PIRATININGA: PÍER

## ► PÍER

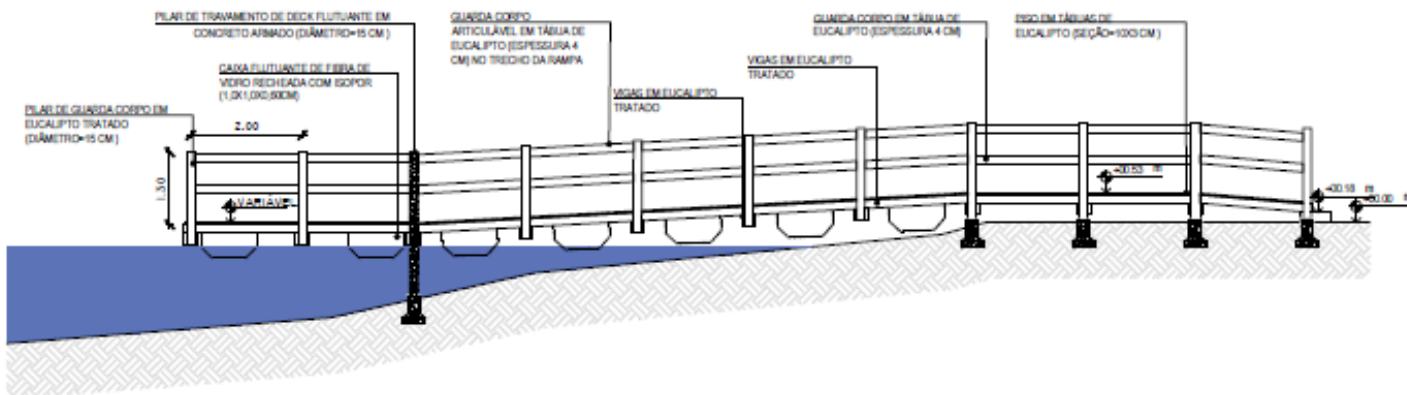

# PARQUE ORLA PIRATININGA: Trecho 8

## ▶ RUA ESTRELA (ANTIGA RUA CEM)



## ▶ TIPOLOGIA VIÁRIA

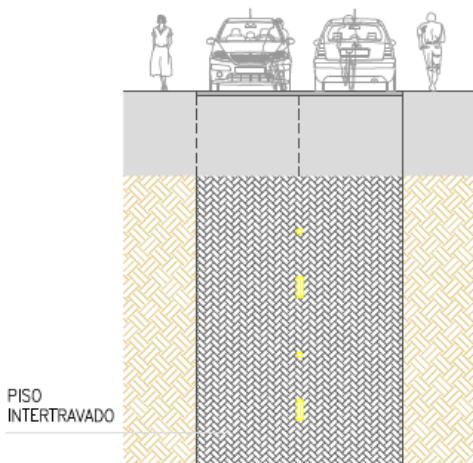

TIPOLOGIA  
LIMITE LOTES PRIVADOS  
CALÇADA 1,50 M  
CICLORROTA BIDIRECIONAL 4,40M  
CALÇADA 1,50 M  
LIMITE LOTES PRIVADOS

- ▶ **Tipologia da via:** Via compartilhada entre ciclistas e veículos motorizados em ambos os sentidos.
- ▶ **Pavimentação:** Bloco intertravado até a última edificação da rua e saibro cimento no trecho restante
- ▶ Necessária normatização para tráfego em baixa velocidade adotando-se orientações expressas na sinalização horizontal e vertical de informações e identificação de usos

# PARQUE ORLA PIRATININGA: Trecho 8

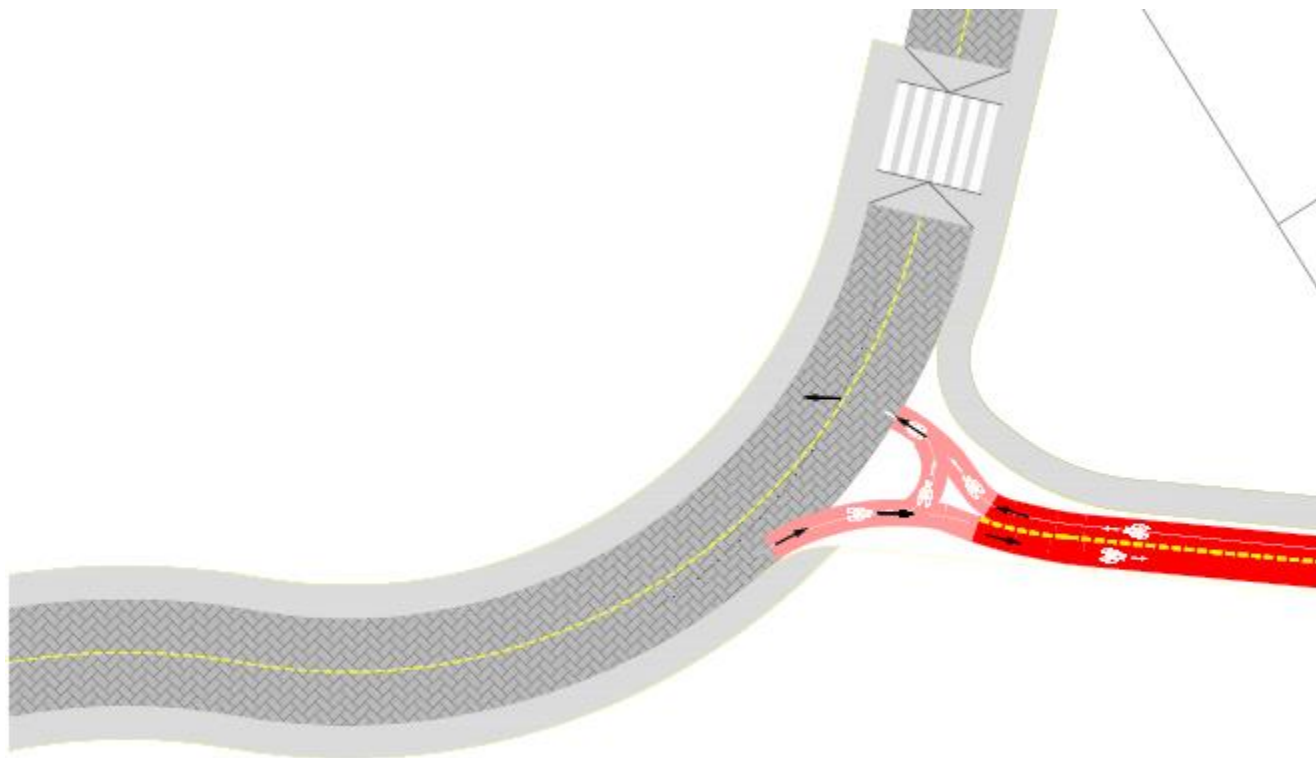



# PARQUE ORLA PIRATININGA: Trecho 8

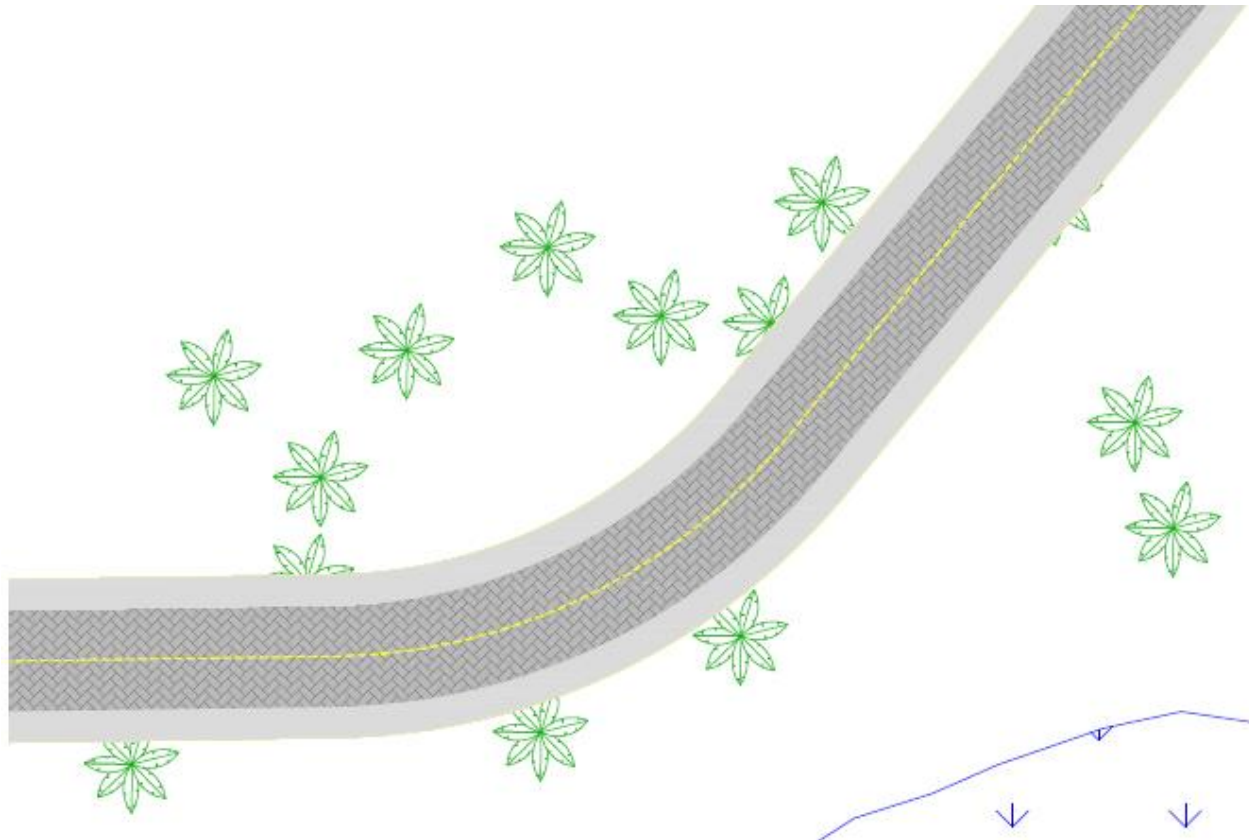

# PARQUE ORLA PIRATININGA: Trecho 8

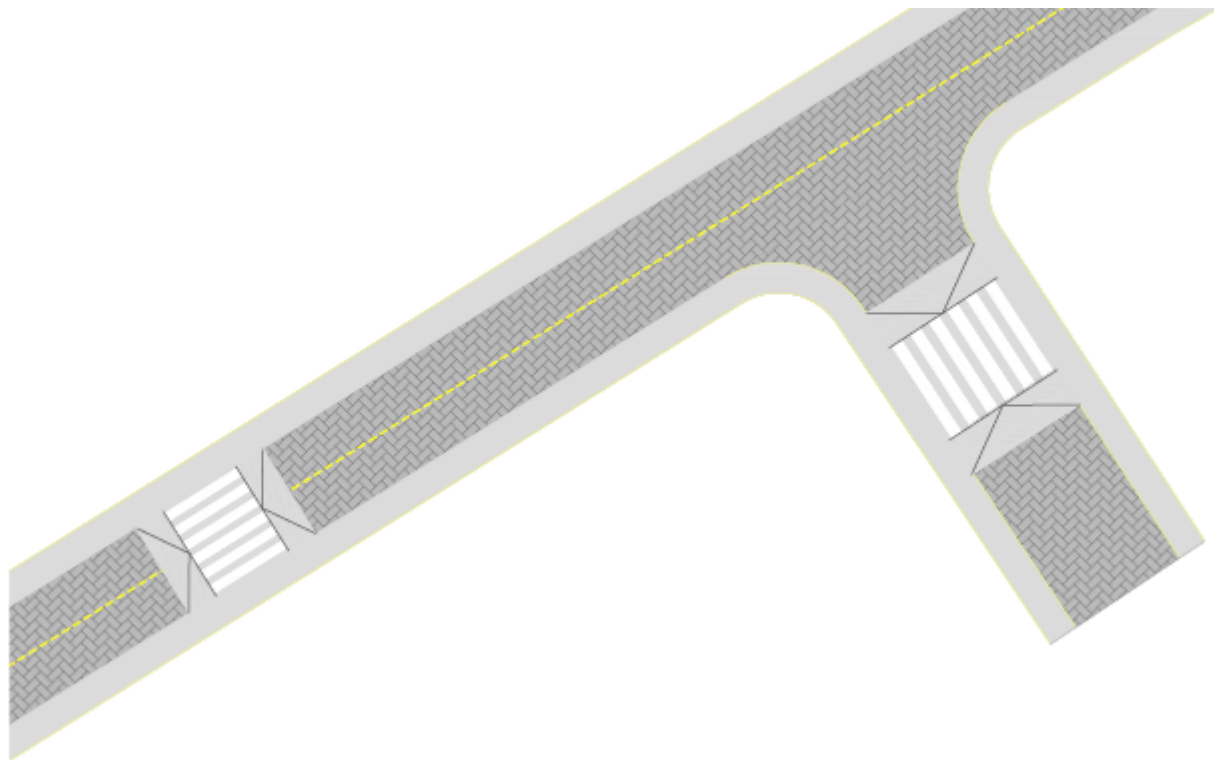

# PARQUE ORLA PIRATININGA: Trecho 8

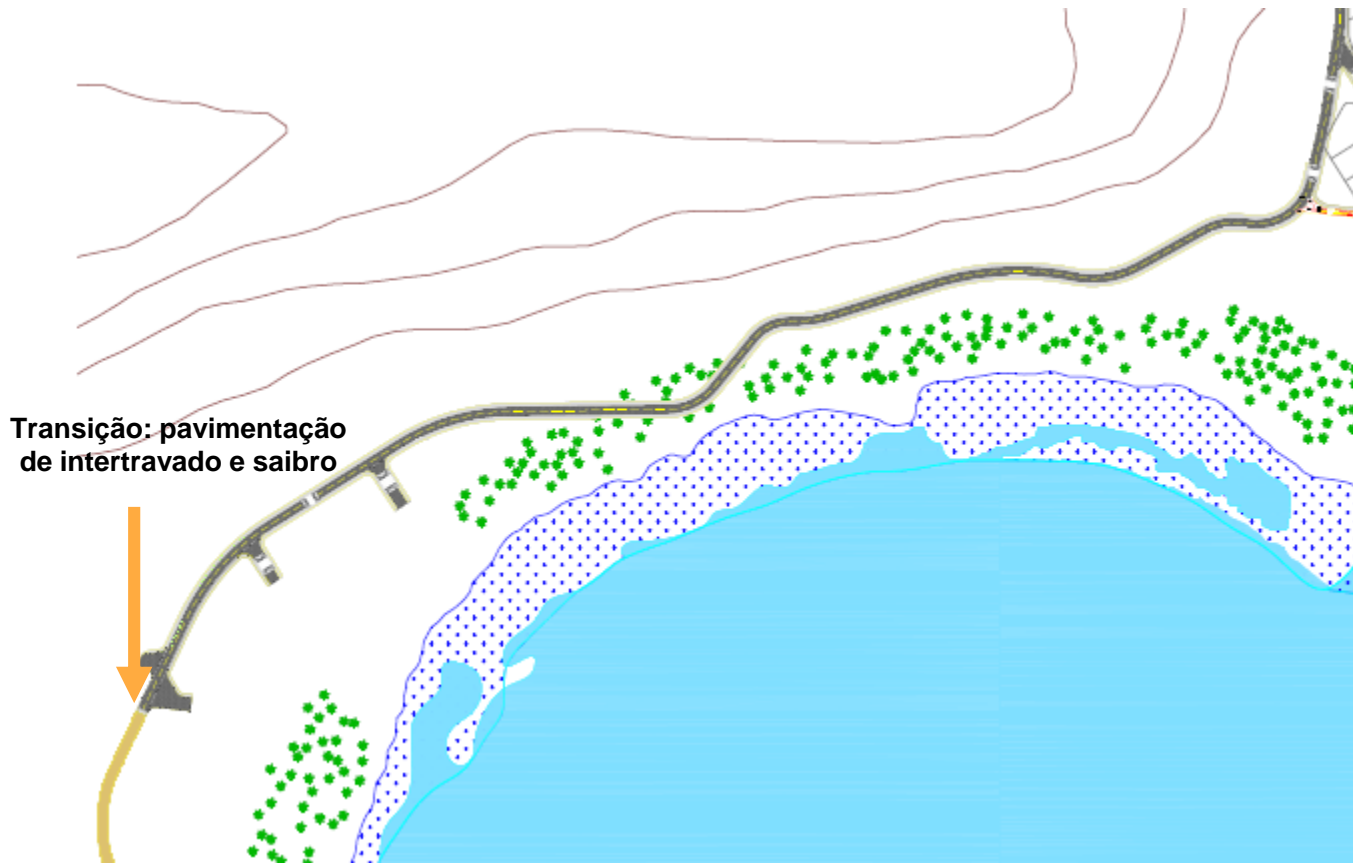

# PARQUE ORLA PIRATININGA: Trecho 8

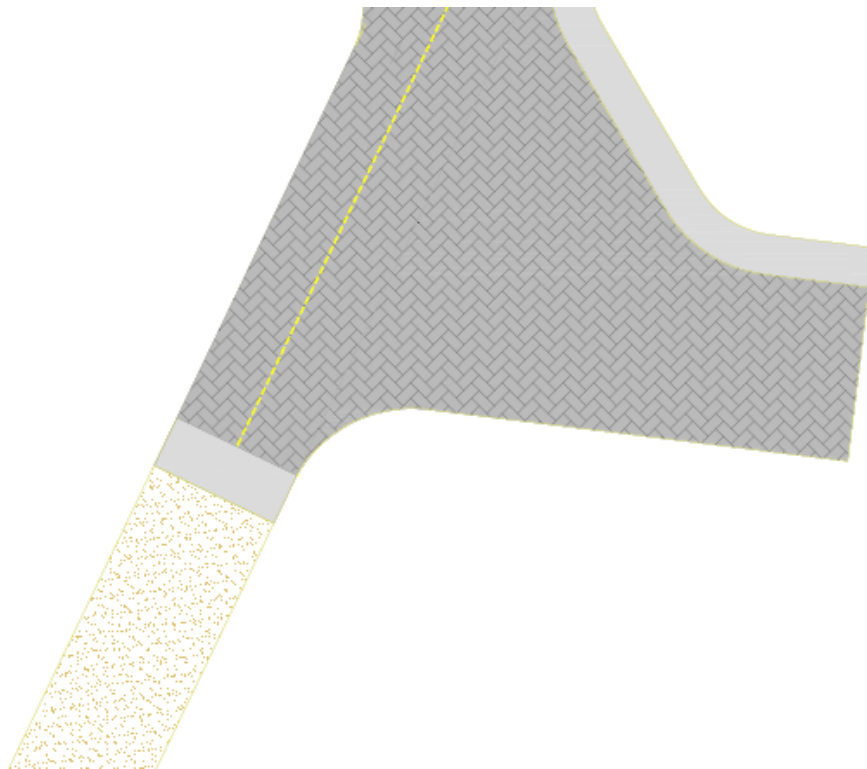



# PARQUE ORLA PIRATININGA: Trecho 8



# PARQUE ORLA PIRATININGA: Trecho 8

## ▶ ÁREA DE ESTAR

- ▶ 4 bancos
- ▶ 2 mesas
- ▶ Paraciclos
- ▶ Piso: saibro cimento

## Localização

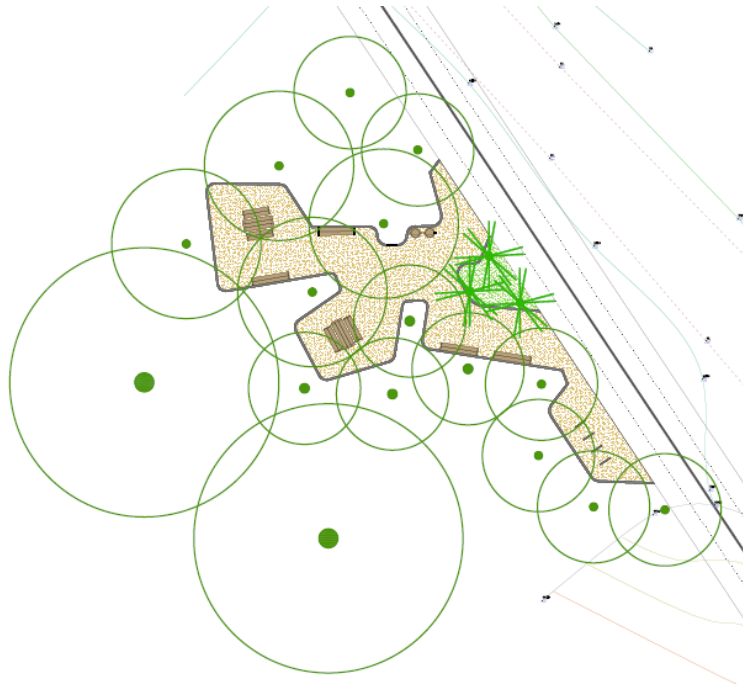
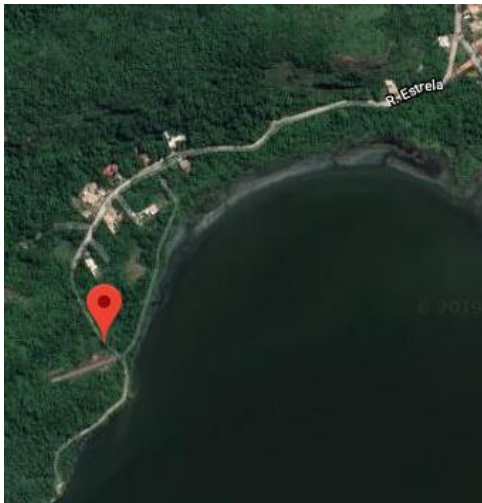

# PARQUE ORLA PIRATININGA: Trecho 8

## ► MOBILIÁRIO

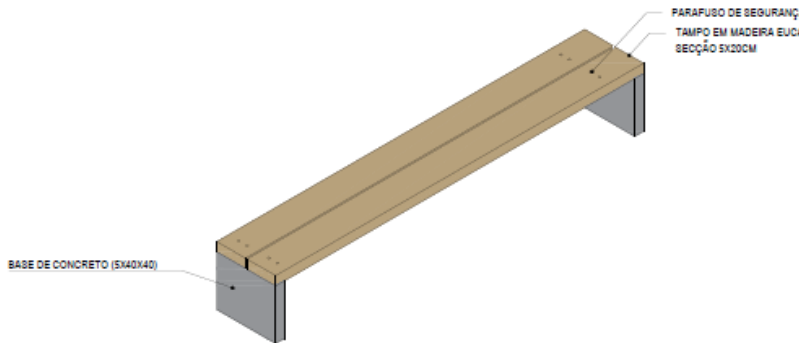

DET. 1 BANCO 1 - ISOMÉTRICA

01 | ESC: 1:25

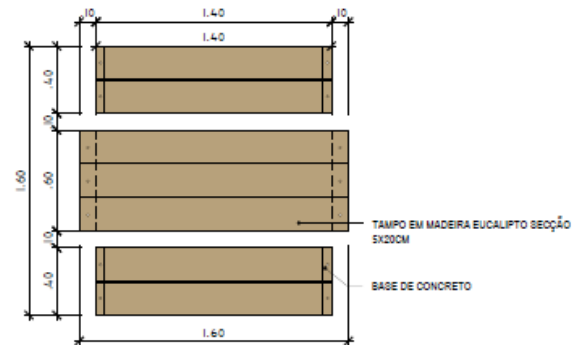

DET. 2 MESA - PLANTA BAIXA

05 | ESC: 1:25

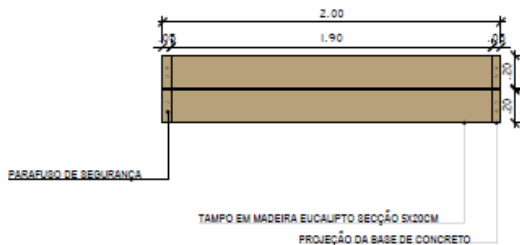

DET. 1 BANCO 1 - PLANTA BAIXA

02 | ESC: 1:25

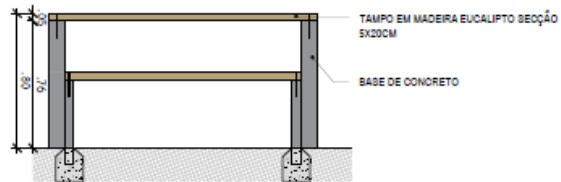

DET. 2 MESA - VISTA FRONTAL

06 | ESC: 1:25

# PARQUE ORLA PIRATININGA: Trecho 8

## ► MOBILIÁRIO

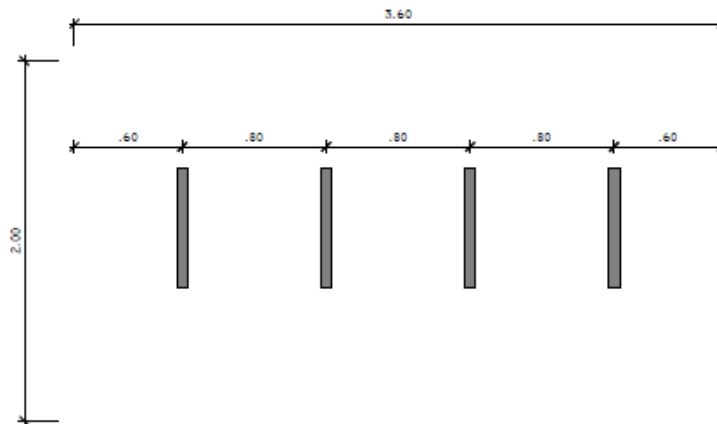

DET. 3 - BICICLETÁRIO

08 | ESC: 1:25

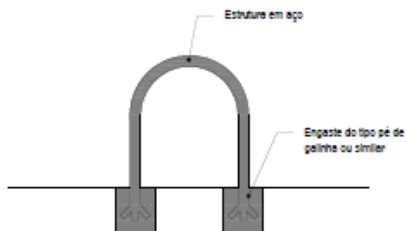

DET. 3 BICICLETÁRIO - VISTA LATERAL

09 | ESC: 1:25



# PARQUE ORLA PIRATININGA: Trecho 8

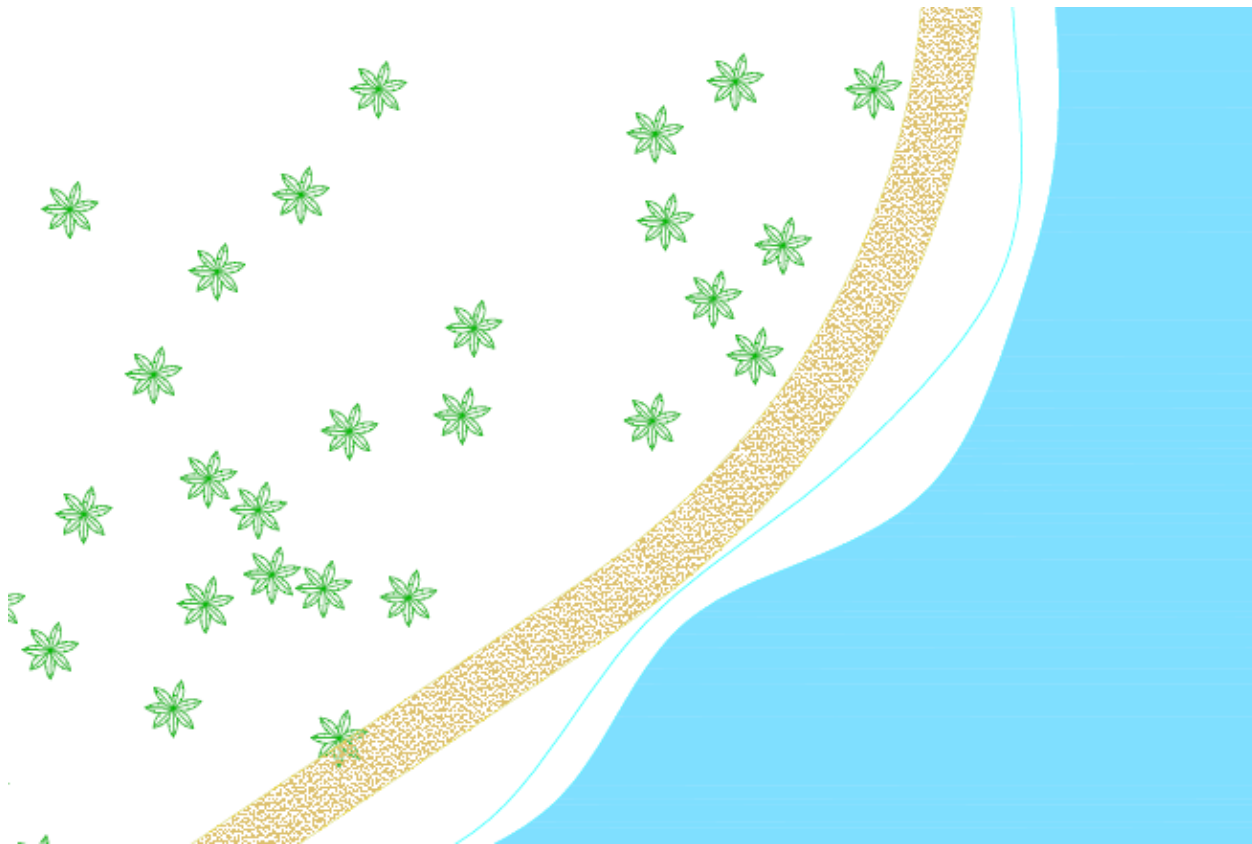

# PARQUE ORLA PIRATININGA: Trecho 8

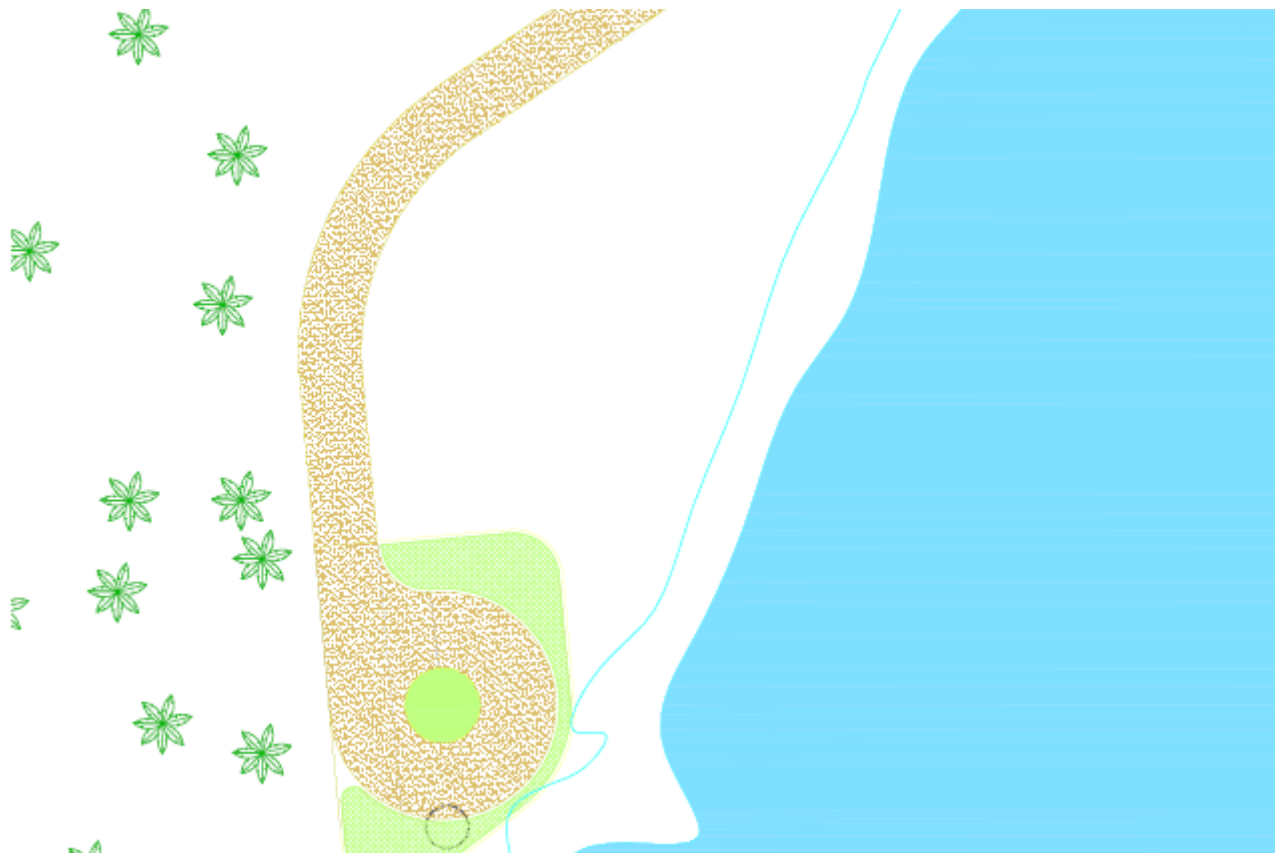

# PARQUE ORLA PIRATININGA: Trecho 9

## ▶ FAZENDINHA



# PARQUE ORLA PIRATININGA: Trecho 9

## ▶ TIPOLOGIA VIÁRIA

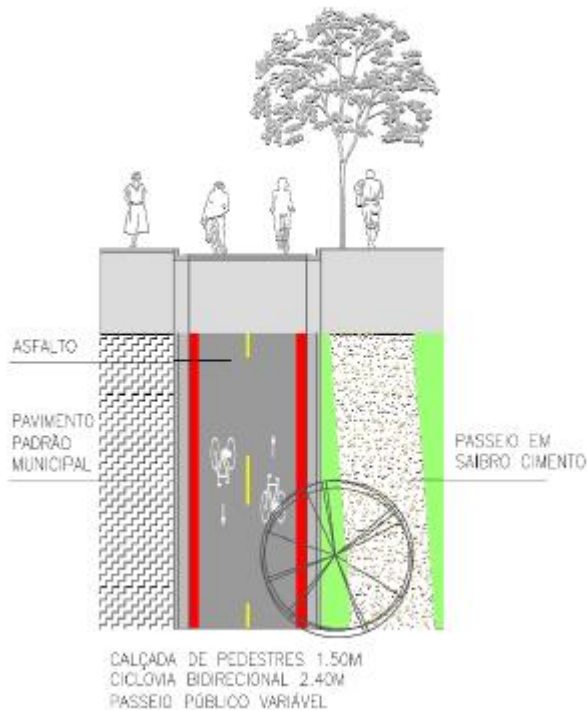

**Tipologia da via:** Calçada, ciclovia bidirecional e passeio público de largura variável

**Pavimentação:** Calçada em concreto, ciclovia em asfalto pigmentado e passeio público em saibro-cimento



# PARQUE ORLA PIRATININGA: Trecho 9



# PARQUE ORLA PIRATININGA: Trecho 9

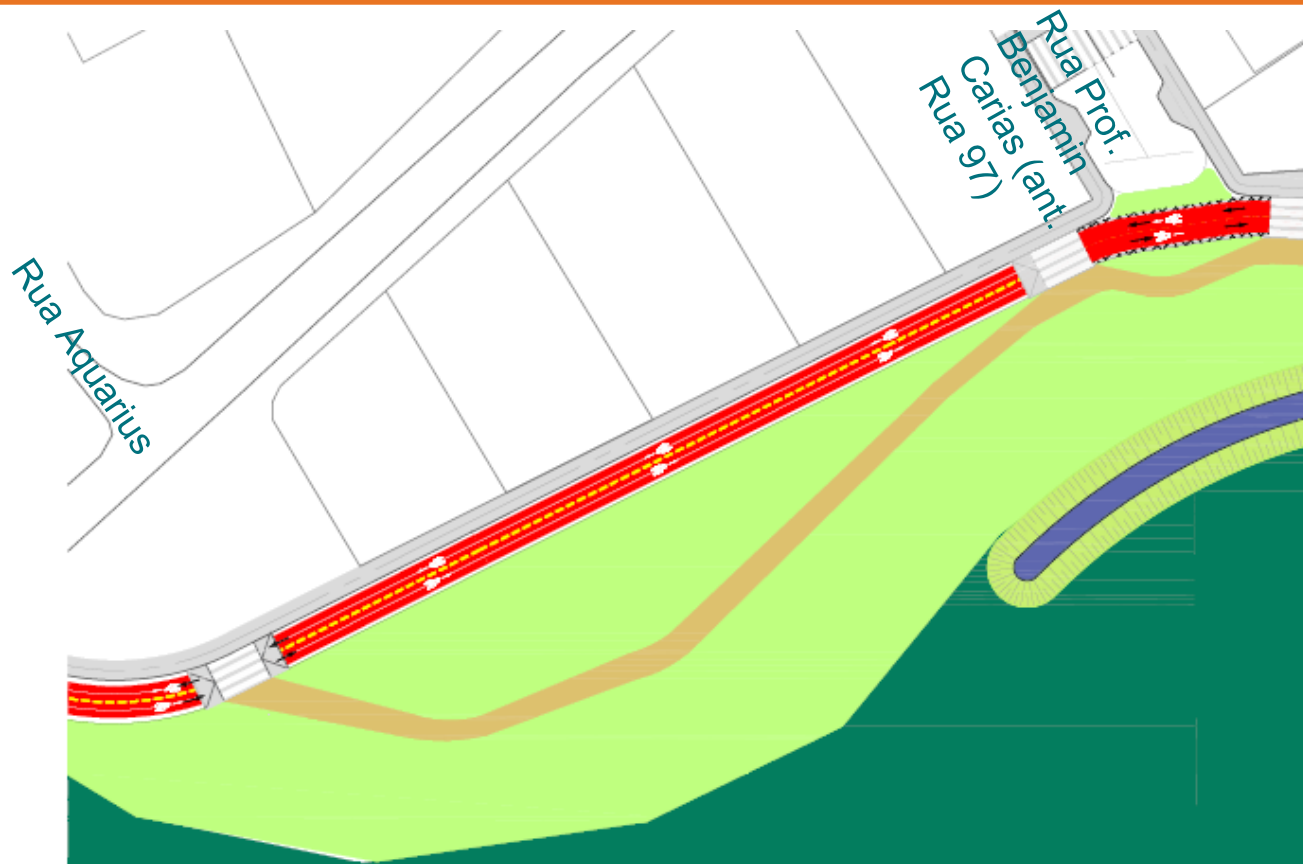

# PARQUE ORLA PIRATININGA: Trecho 9



# PARQUE ORLA PIRATININGA: Trecho 9



# PARQUE ORLA PIRATININGA: Trecho 9



# PARQUE ORLA PIRATININGA: Trecho 9





# PARQUE ORLA PIRATININGA: Trecho 9



# PARQUE ORLA PIRATININGA: Trecho 9



# PARQUE ORLA PIRATININGA: Trecho 9

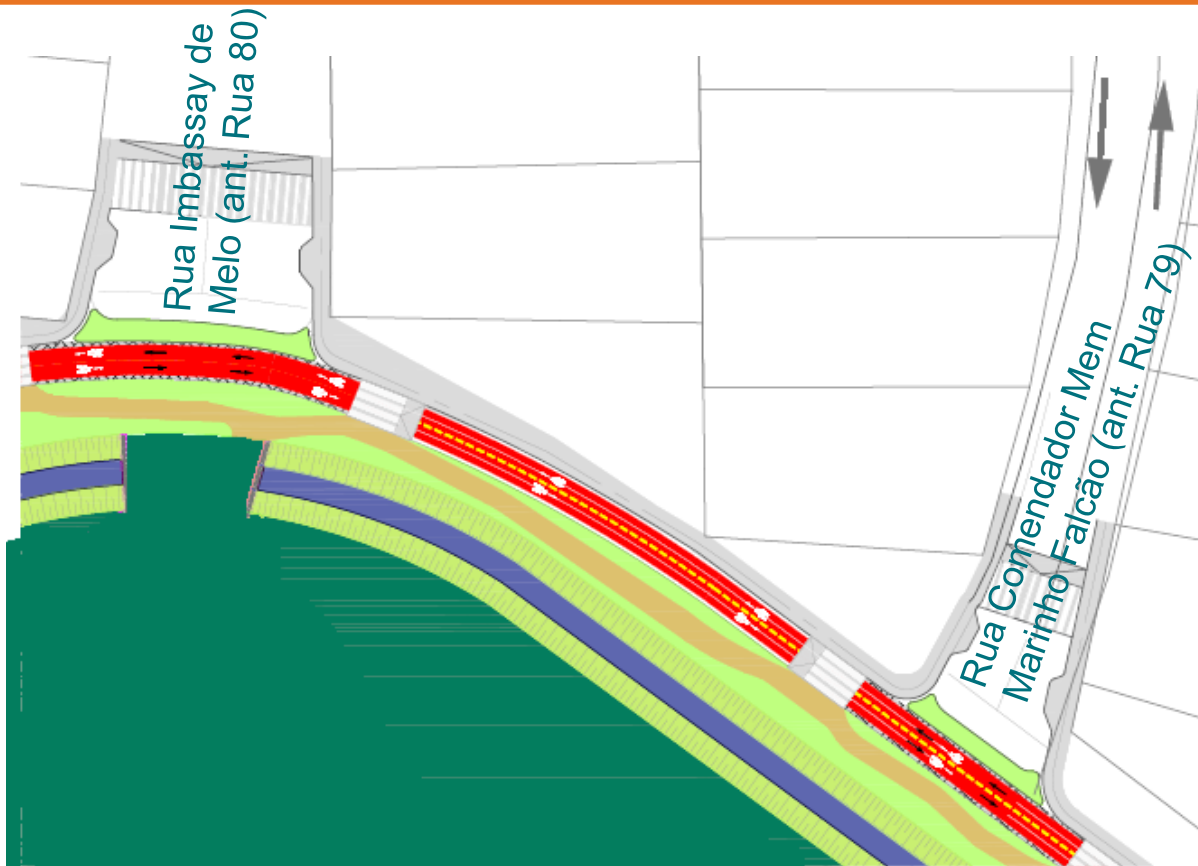

# PARQUE ORLA PIRATININGA: Trecho 9



# PARQUE ORLA PIRATININGA: Trecho 9

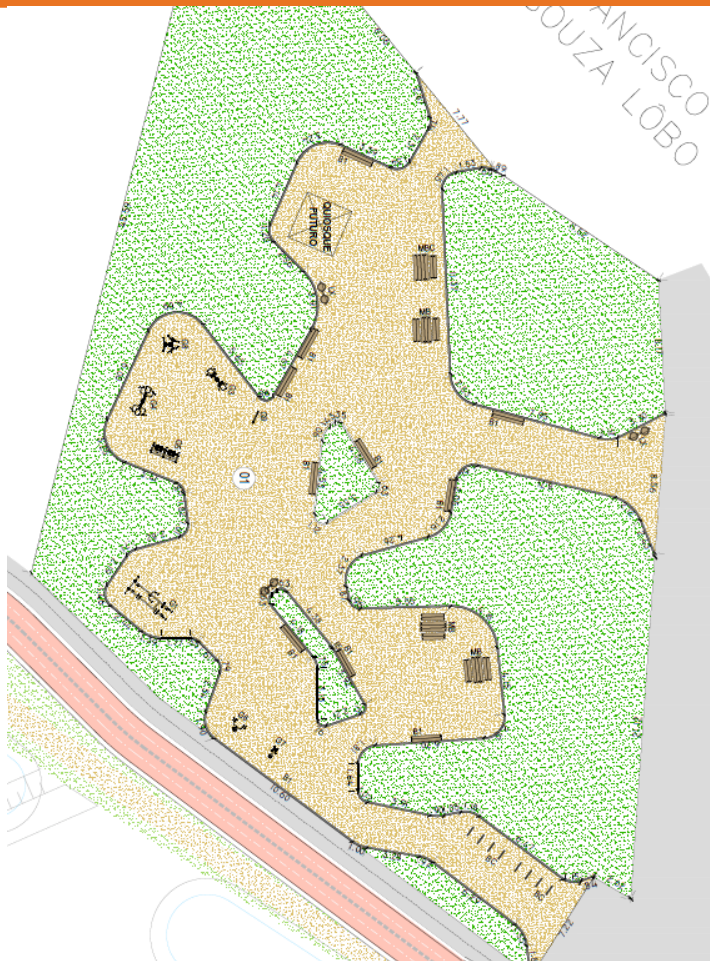

- ▶ 10 bancos
- ▶ 4 mesas
- ▶ Paraciclos
- ▶ Equipamentos de ginástica
- ▶ Piso: saibro cimento

## Localização





# PARQUE ORLA PIRATININGA: Trecho 9





## ▶ ESTUDO DE LOCALIZAÇÃO DO MIRANTE

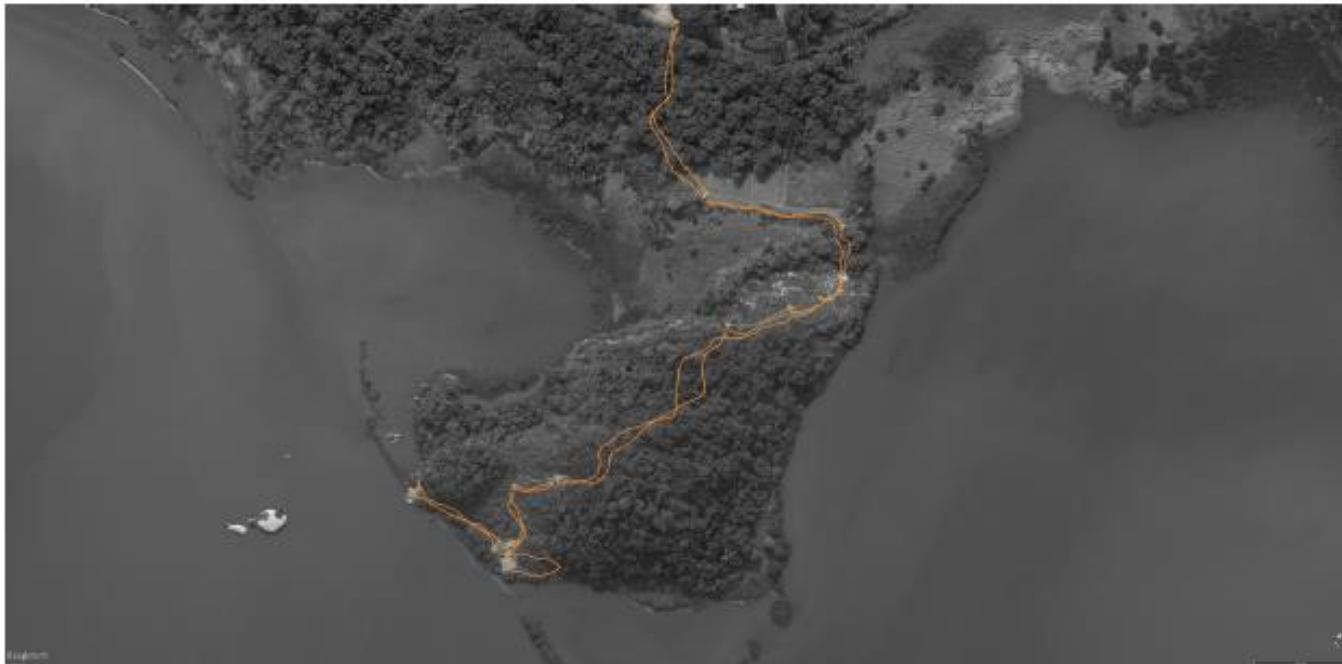

# PARQUE ORLA PIRATININGA: Trecho 9

## ▶ ESTUDO DE LOCALIZAÇÃO DO MIRANTE



# PARQUE ORLA PIRATININGA: Trecho 9

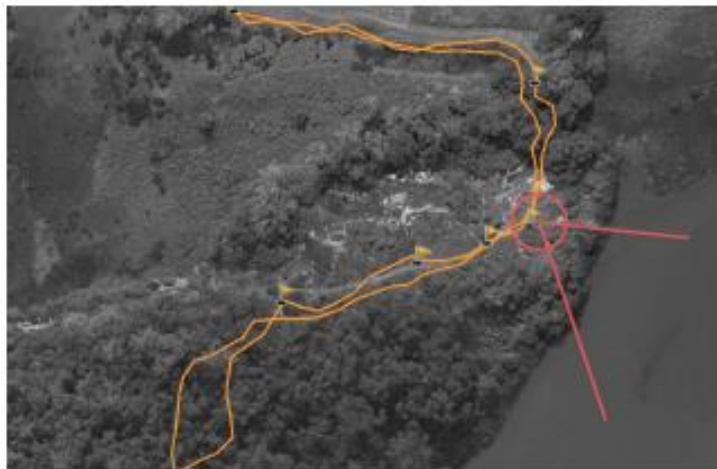

VISTA

# PARQUE ORLA PIRATININGA: Ilha do Pontal

## ► MIRANTE

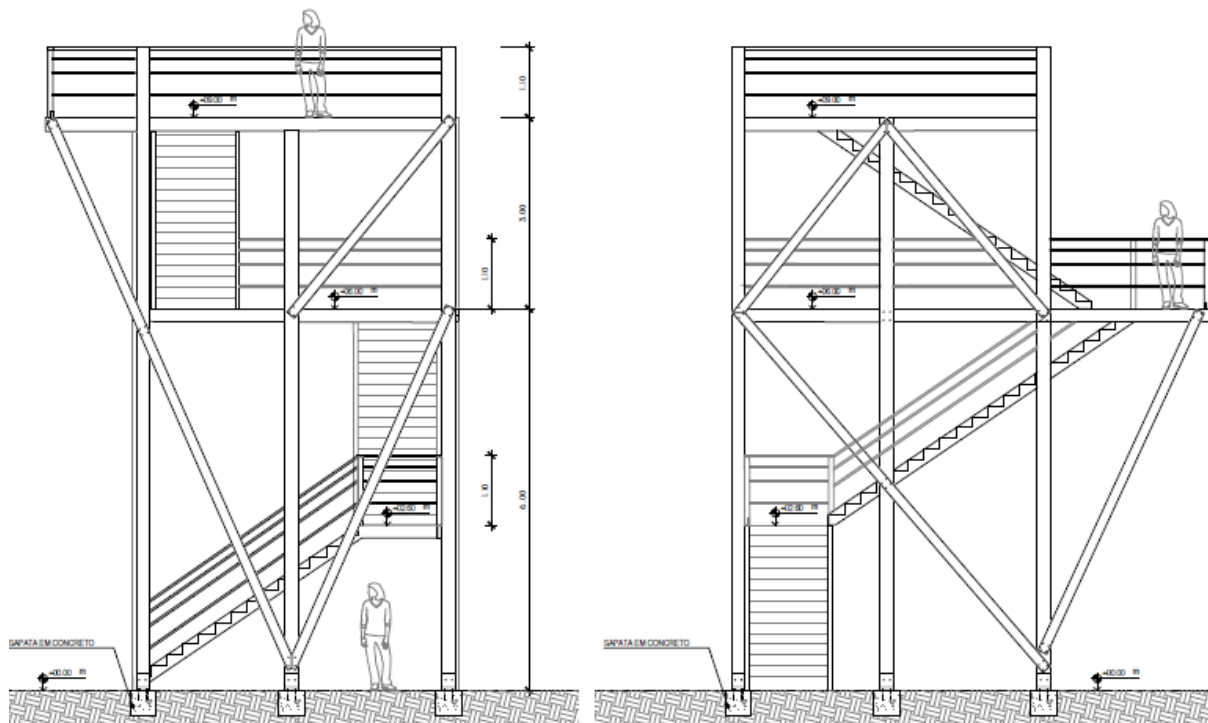



---

# INFRAESTRUTURA VERDE

---

# INFRAESTRUTURA VERDE

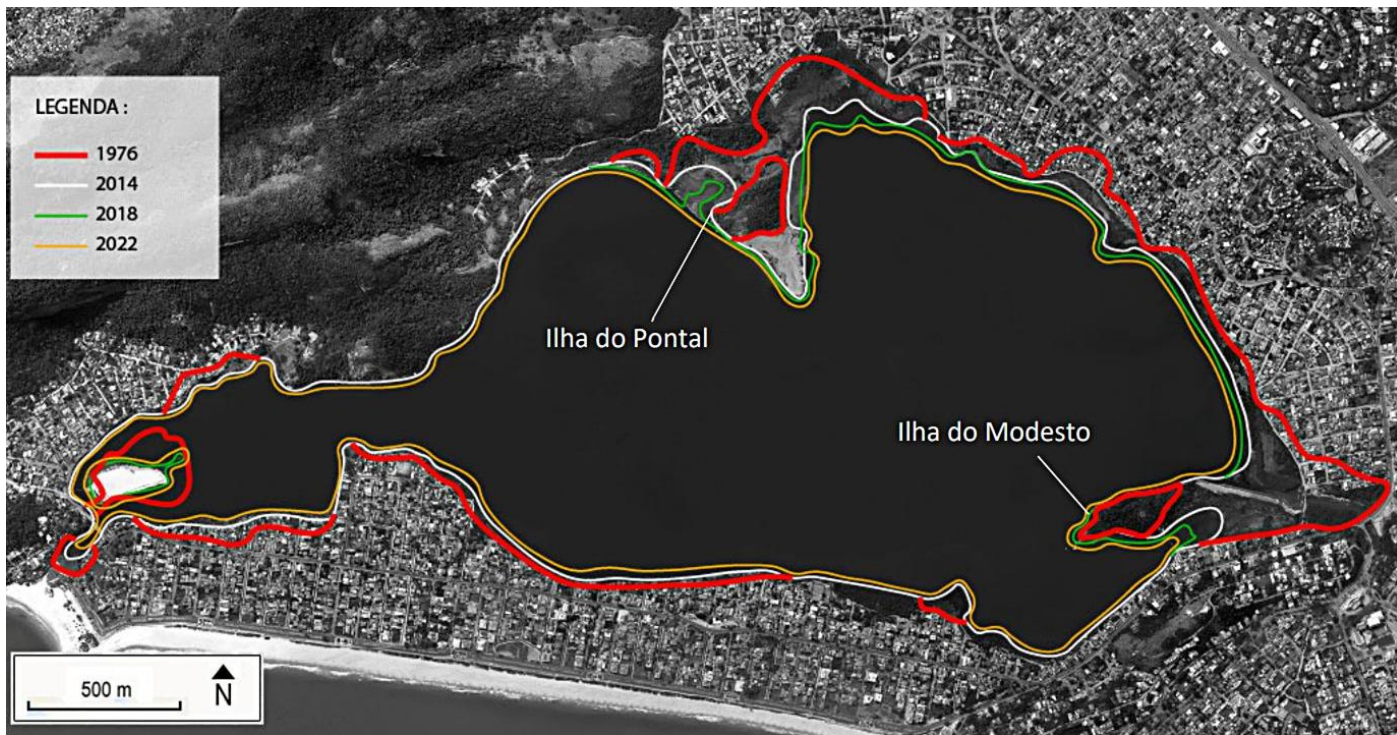

Fonte: Elaborado por Phytorestore baseado em estudo realizado por FONTENELLE T.H. e CÔRREA W.B. – Universidade Federal Fluminense Rio de Janeiro  
"Impacto da urbanização no espelho d'água do sistema lagunar de Itaipu e de Piratininga Niterói (RJ), Maio – Agosto 2014; Foto de satélite utilizada do Google Earth.



# INFRAESTRUTURA VERDE: Alagados construídos

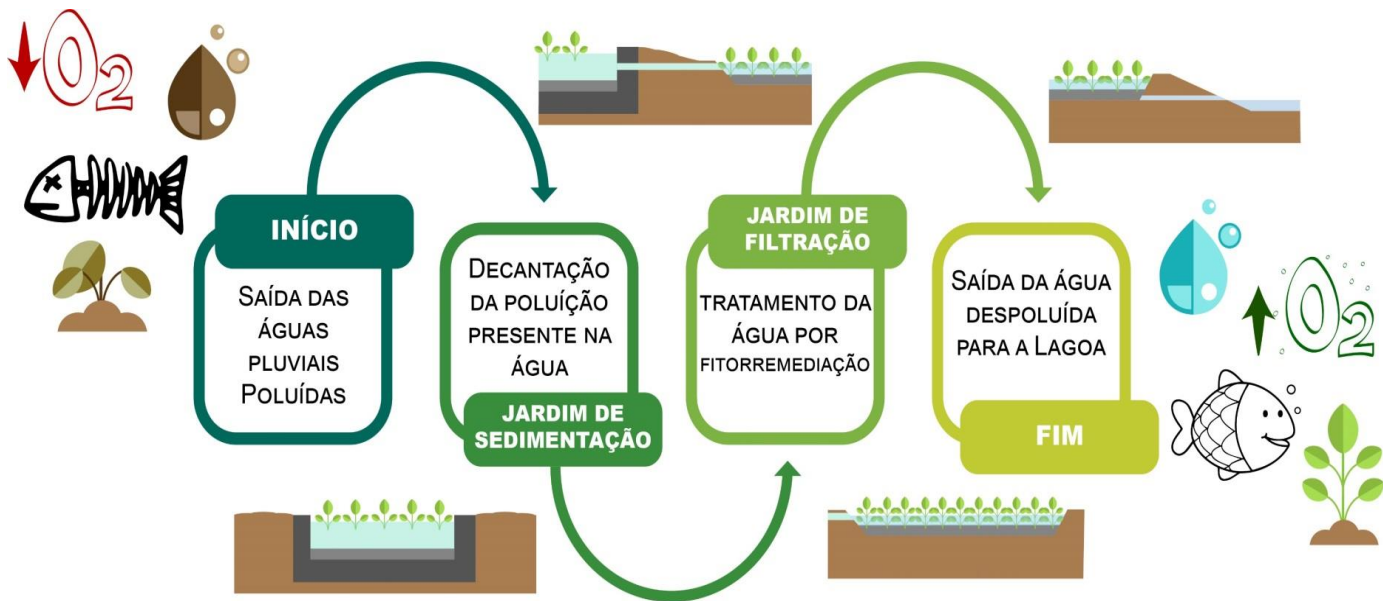

# INFRAESTRUTURA VERDE: Alagados construídos

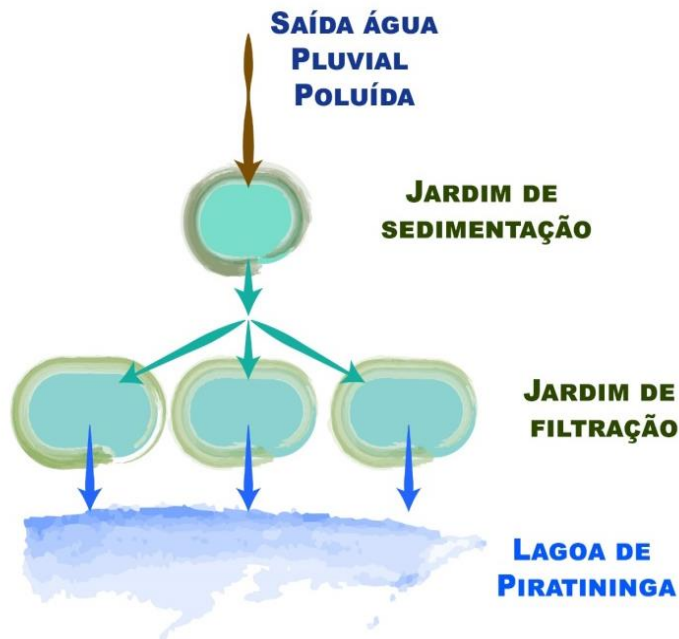

# INFRAESTRUTURA VERDE: Alagados construídos

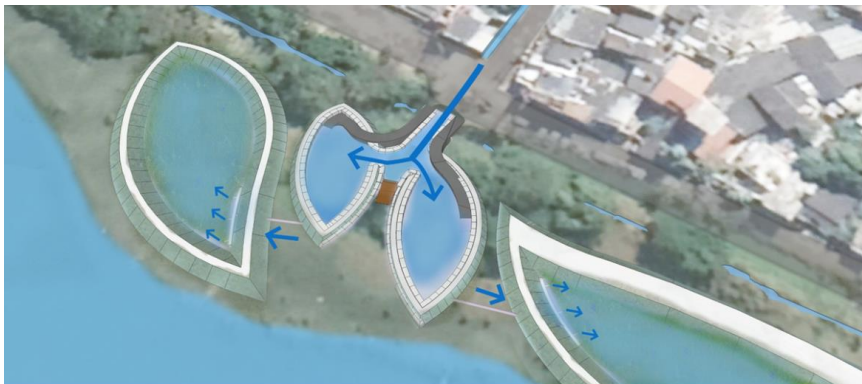

---

Funcionamento do sistema de alagados construídos durante o período sem chuvas

---

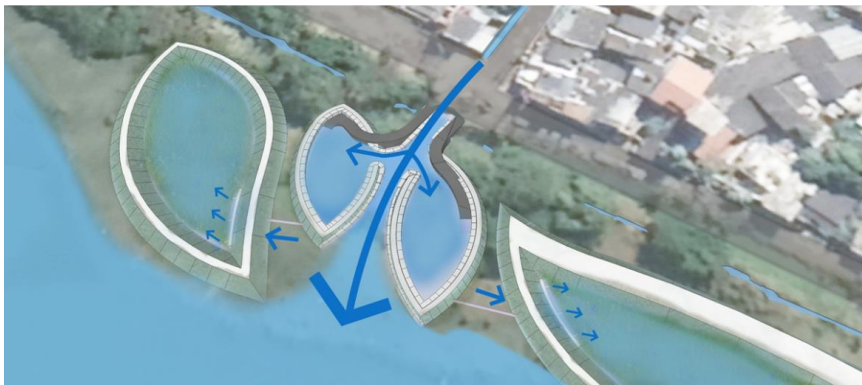

---

Funcionamento do sistema de alagados construídos durante o período chuvoso

---



---

AMOSTRAS DE ÁGUAS  
PLUVIAIS

---

# INFRAESTRUTURA VERDE: Alagados construídos

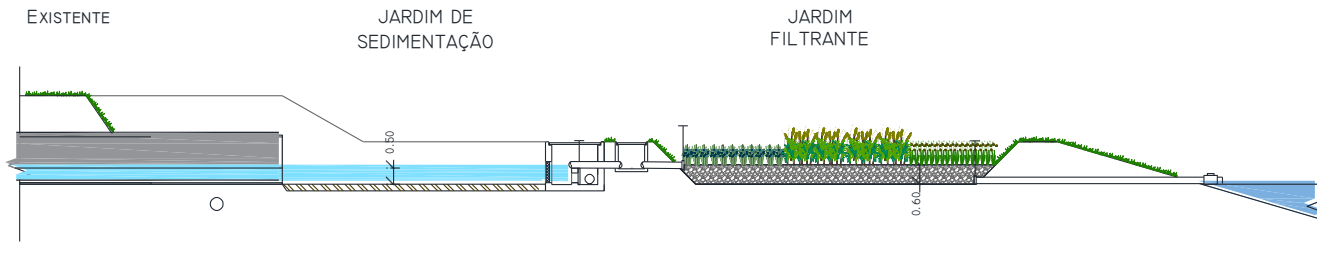
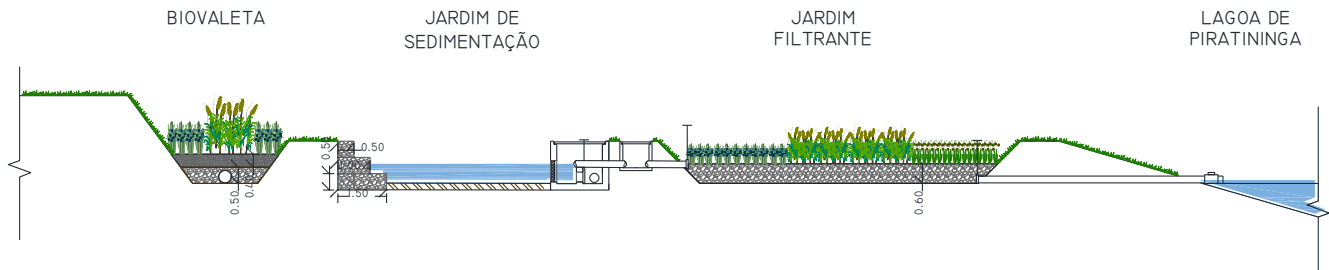

# INFRAESTRUTURA VERDE: Alagados construídos

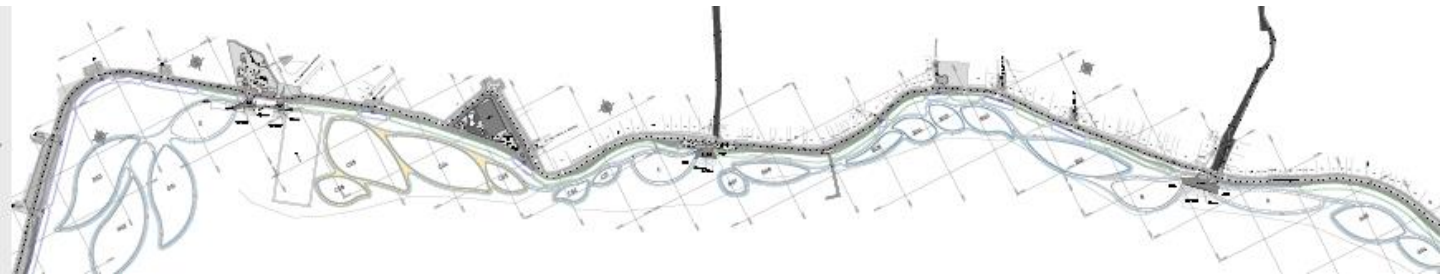

TRECHOS 9 e 1



# INFRAESTRUTURA VERDE: Alagados construídos

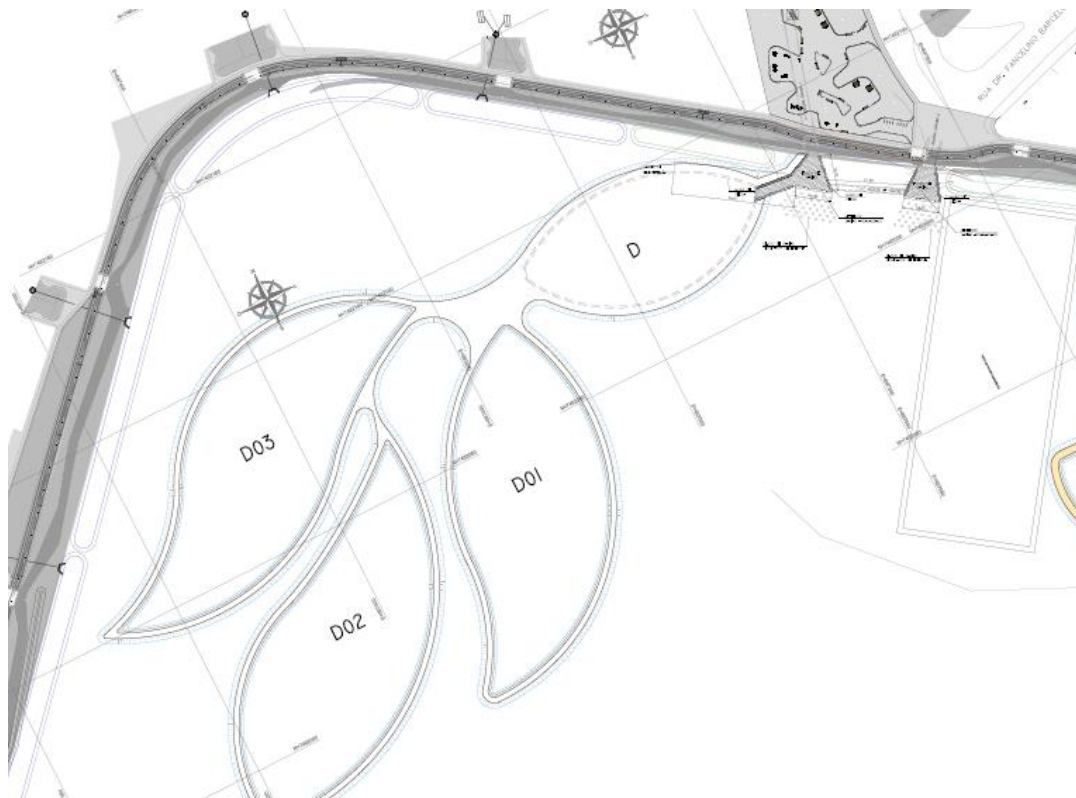

# INFRAESTRUTURA VERDE: Alagados construídos

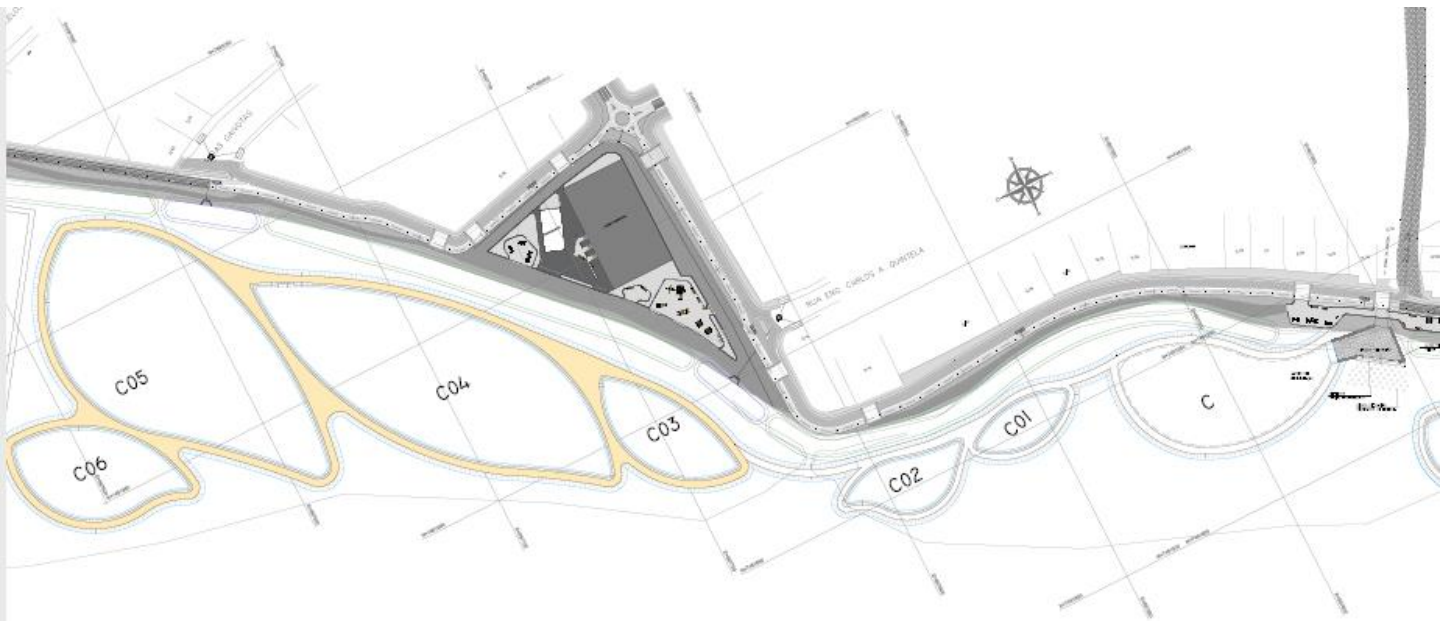

# INFRAESTRUTURA VERDE: Alagados construídos

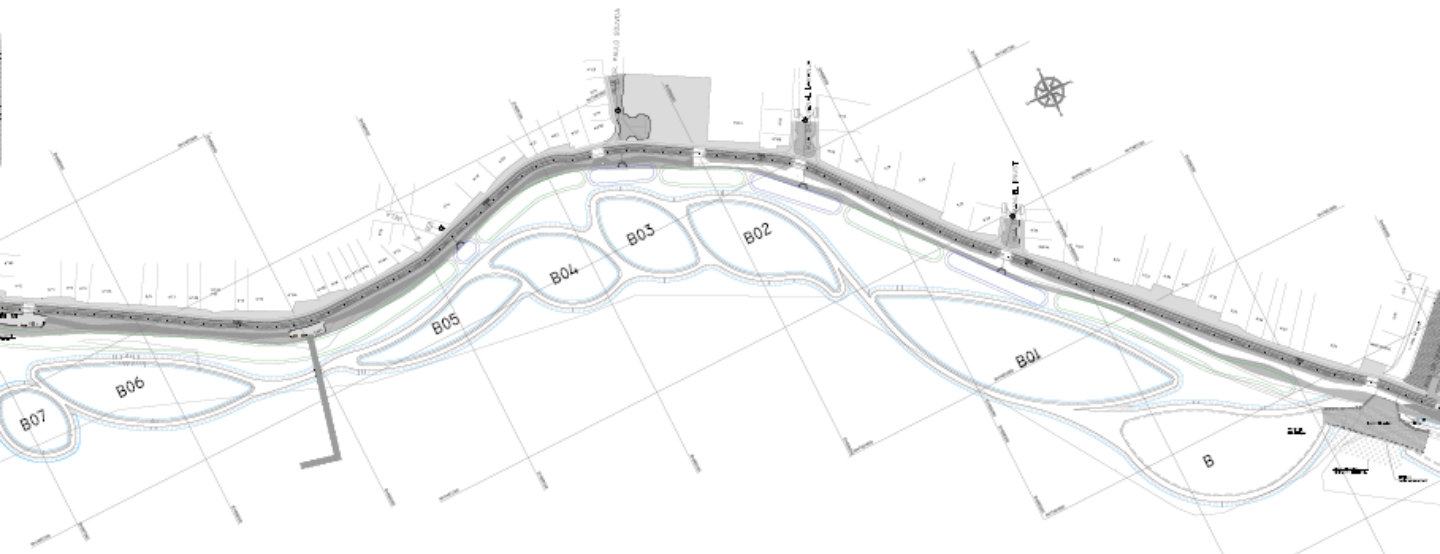

# INFRAESTRUTURA VERDE: Alagados construídos

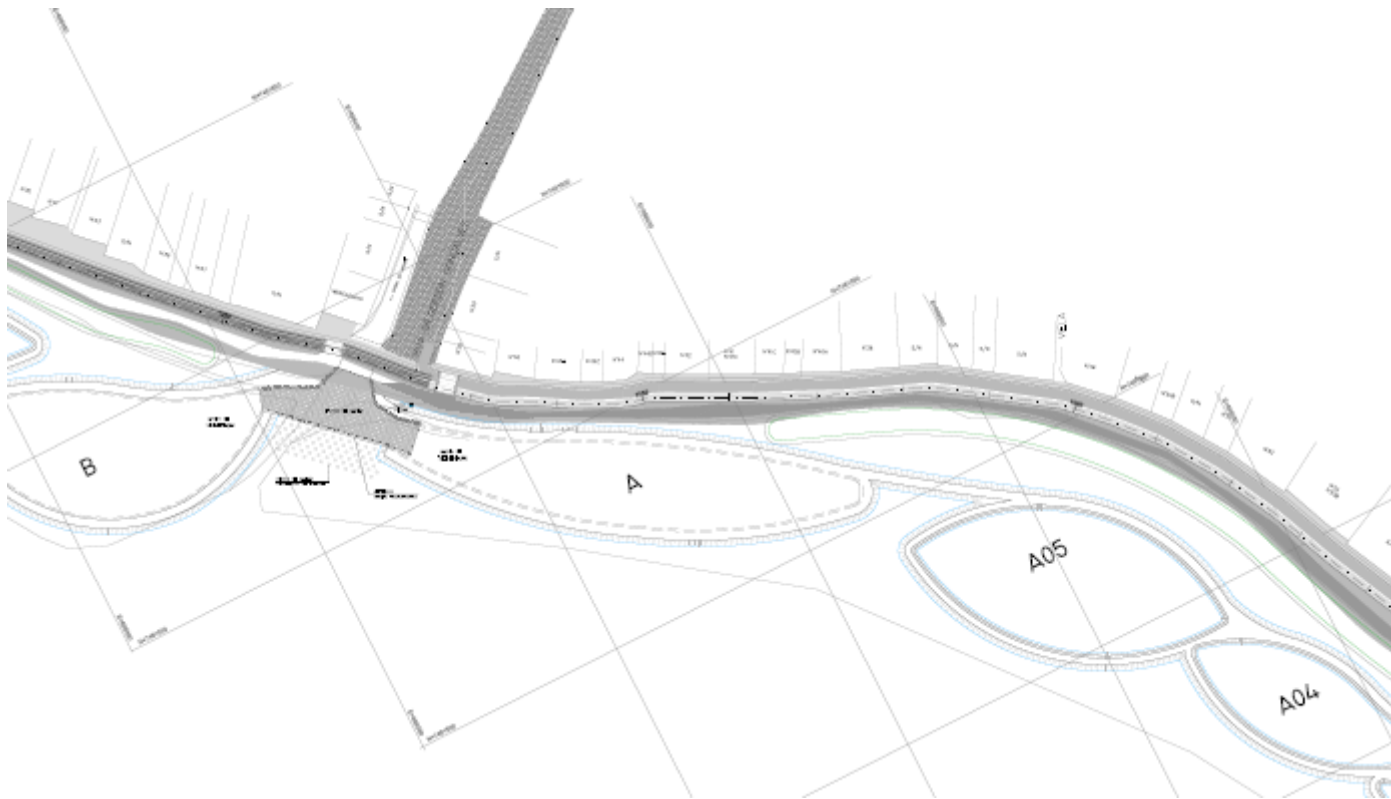

# INFRAESTRUTURA VERDE: Alagados construídos



**SITUAÇÃO ATUAL**

**SITUAÇÃO ESPERADA (Referência)**



# INFRAESTRUTURA VERDE: Alagados construídos



JARDINS  
FILTRANTES

RECOMPOSIÇÃO  
VEGETAL

JARDIM DE CHUVA  
(Canal de cintura  
reformulado)



# INFRAESTRUTURA VERDE: Alagados construídos

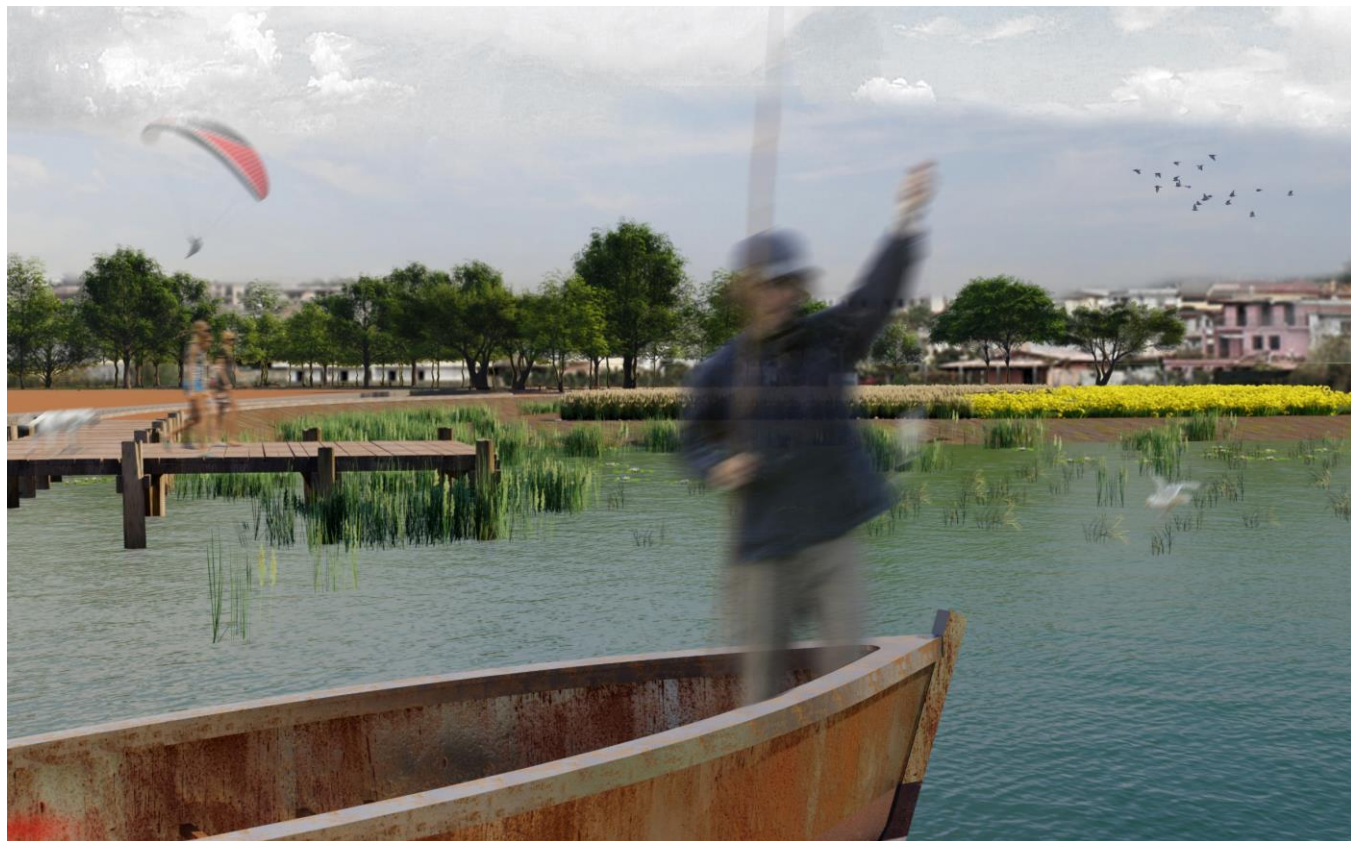



# INFRAESTRUTURA VERDE: Jardins de chuva

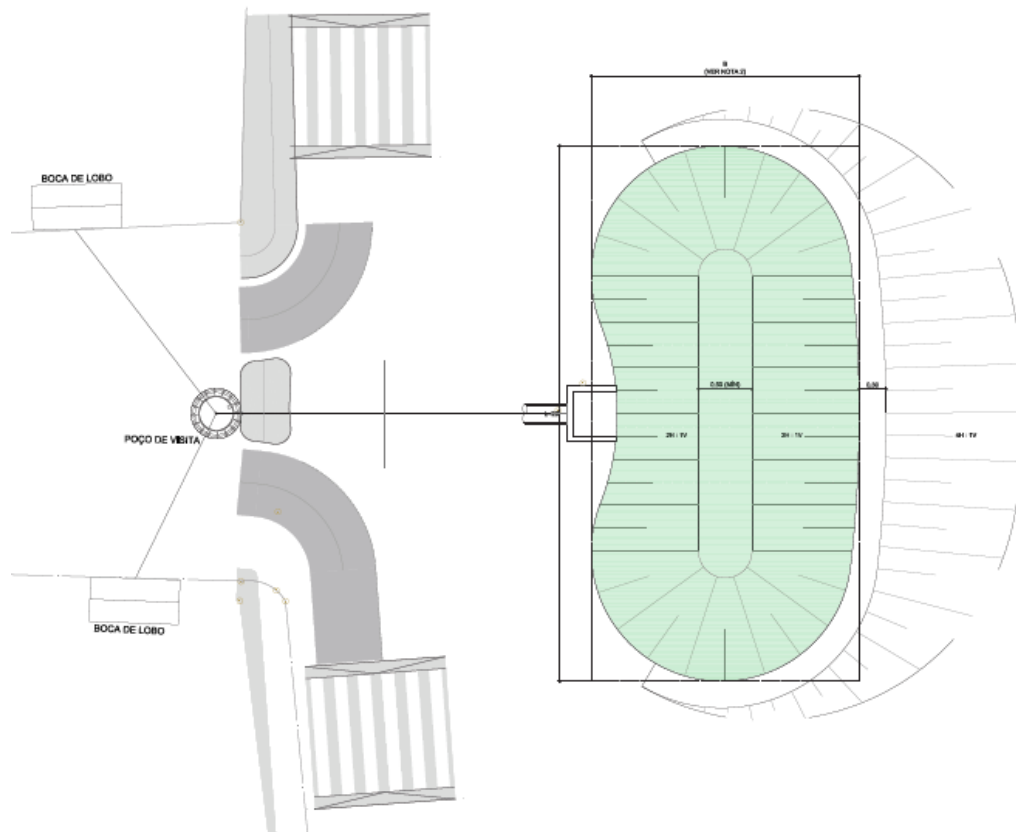

# INFRAESTRUTURA VERDE: Jardins de chuva

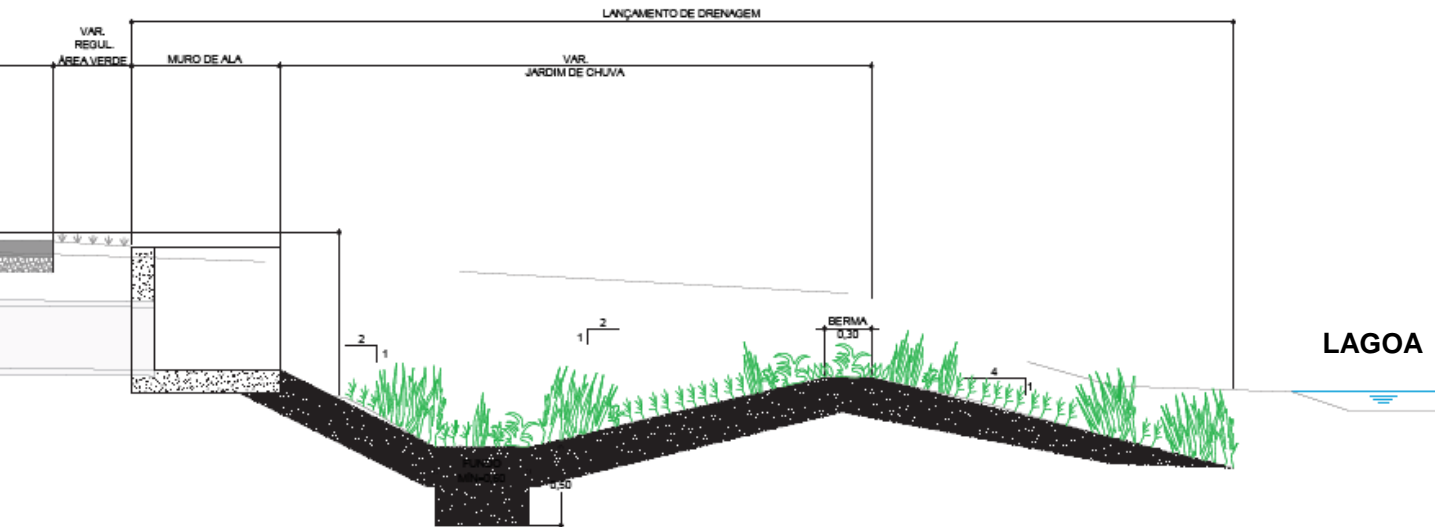



---

[www.prosustentavel.niteroi.rj.gov.br](http://www.prosustentavel.niteroi.rj.gov.br)

[ugpcaf.niteroi@gmail.com](mailto:ugpcaf.niteroi@gmail.com)

Tel: 2620-6609